

# Liberty

11/12/13 m<sup>3</sup>

Self-Propelled



## RMH Mechanical ECO Self-Propelled Mixers Liberty Family

Available Capacity: Single auger 11m<sup>3</sup>, 12m<sup>3</sup> or 13m<sup>3</sup>. The Liberty is Maneuverable and agile self-Propelled Self-Loading thanks to the rear steering axle and compact physical dimensions, design for individual professional farm.

The Liberty has improved feed quality and waste reducing processing method.

The Liberty is energy efficient less than 0.9 Liter/TMR ton and highly reliable machine, with

a range of features which reduce engine and pump wear and increase components' life-time.

Load sensing hydraulic systems allow oil flow only when required. Diesel engine operates at 1700 rpm.

Main machine components are all manufactured by well-known manufactures - Deutz, Sauer Danfoss and Bosch Rexroth hydraulics.

# A cost effective self-propelled

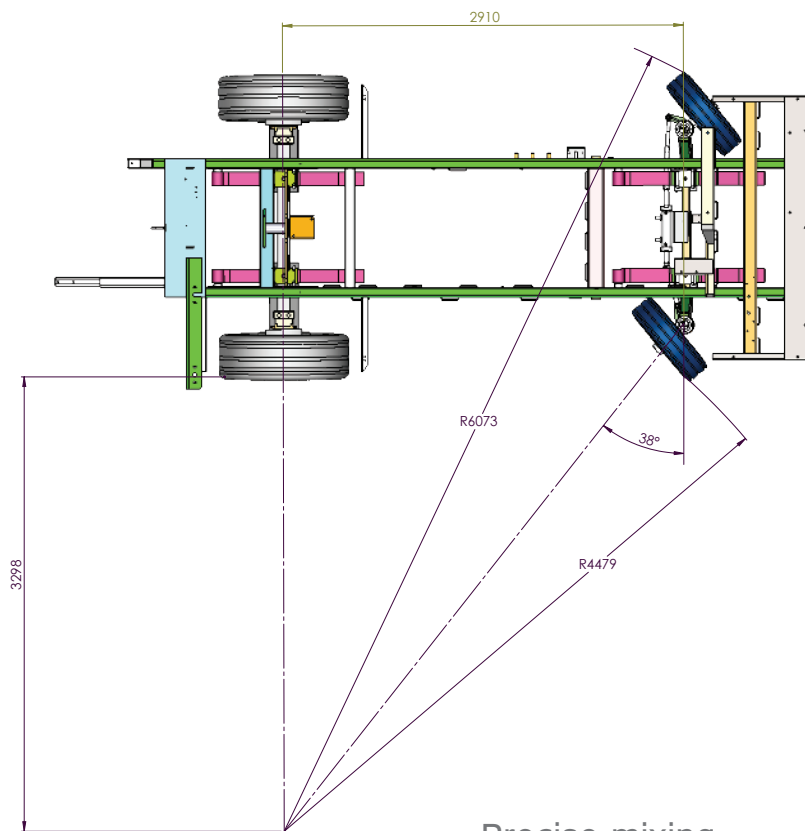

Precise mixing

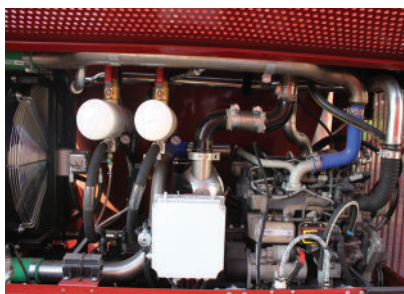
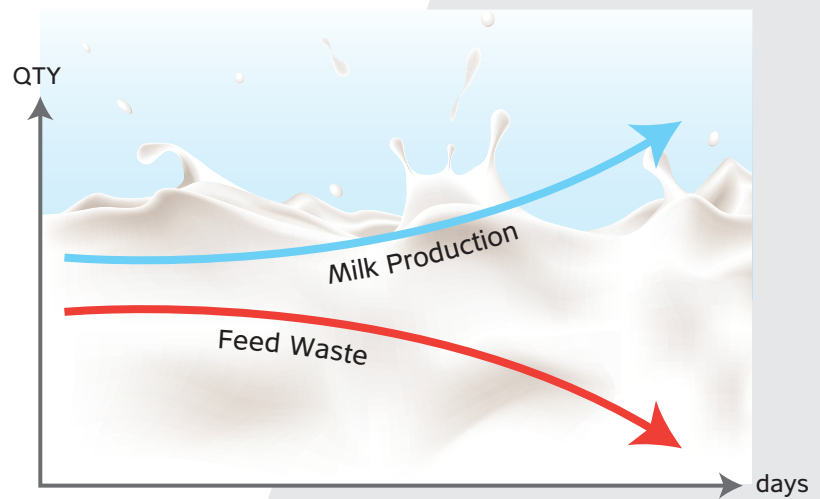

Easy service access



Drum conveyor

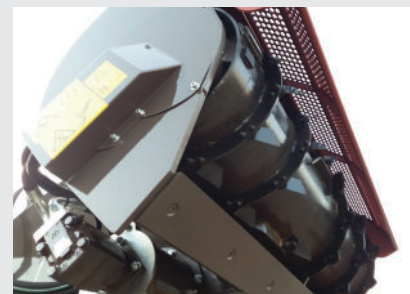

Rigid chopper auger

# High Standard

Vertical auger with 3CR12 stainless steel welded on the edge of the segments.

Mixing bin one-meter height from the floor surrounding made from 3CR12 stainless steel.

Printed electrical board integrated with PLC - Energy Consumption Management.

Bumper shutdown.

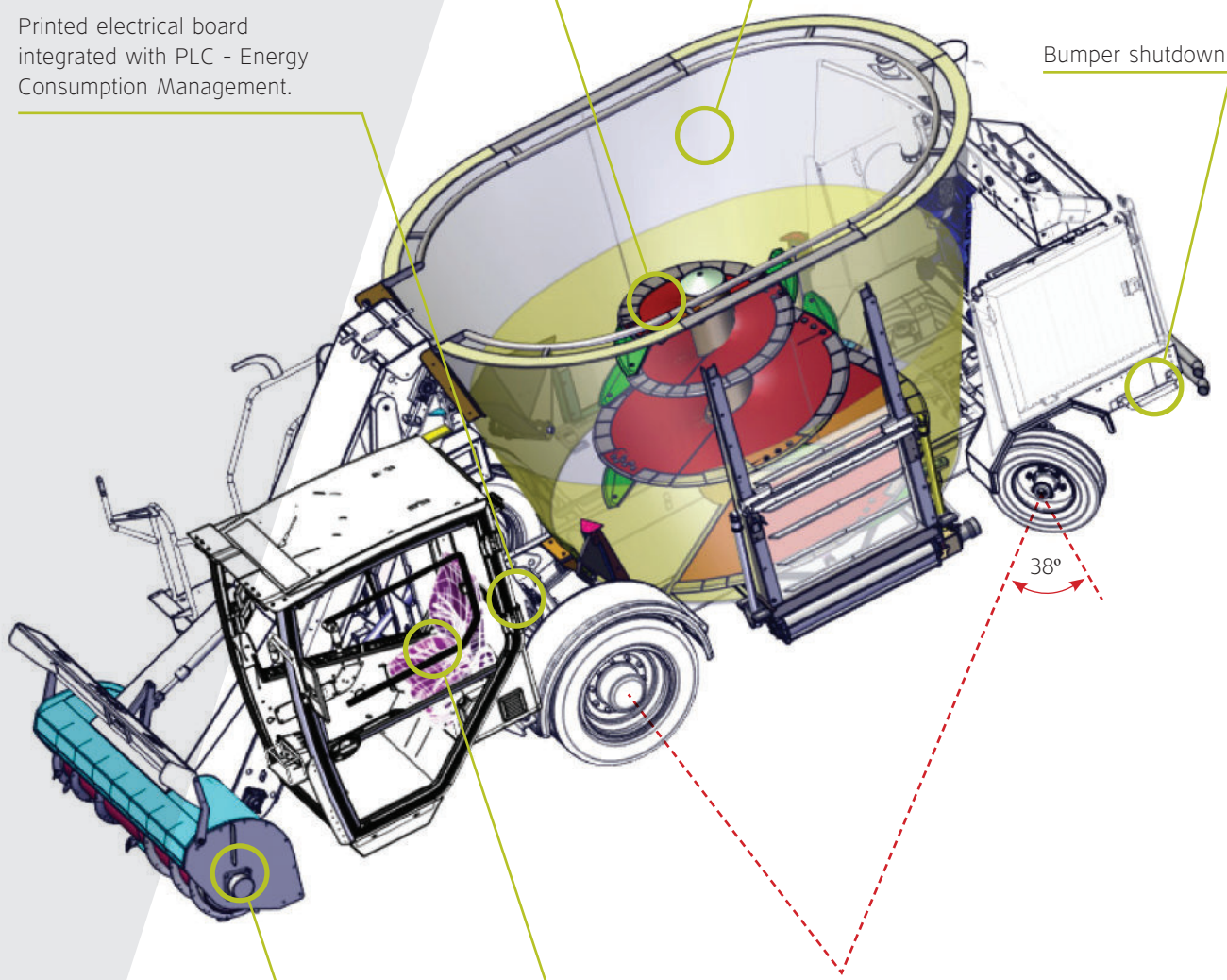

Front spiral chopper, housing made from 3CR12 stainless steel.

Actimo pneumatic seat XXL Grammer.



Hydraulic funnel and contra knives



Folding conveyor

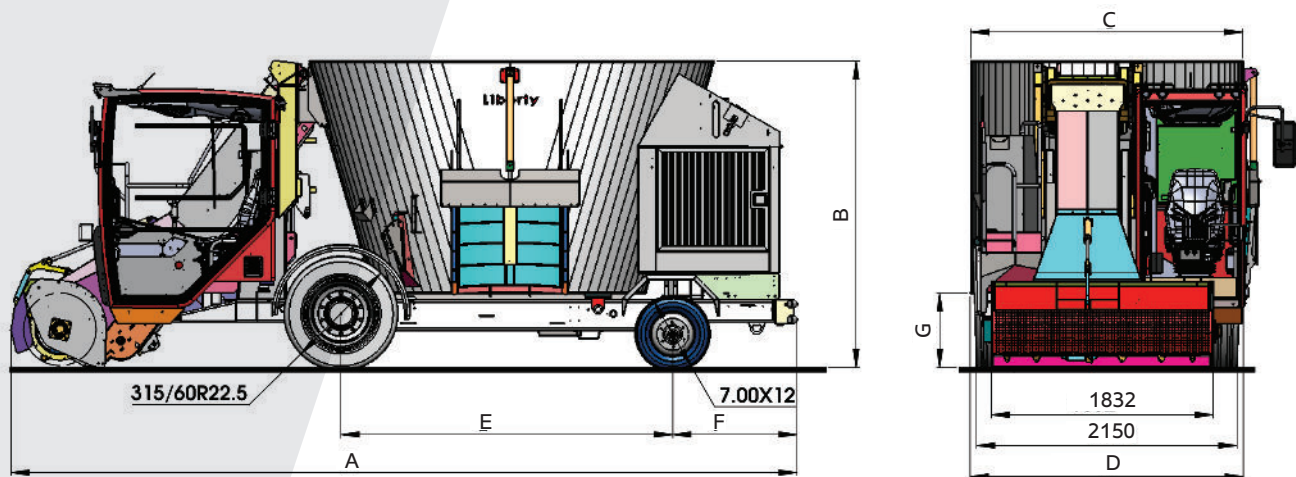

Model	Volume (M <sup>3</sup> )	Net weight	Max Load	Max gross weight	General Dimensions in millimeters							
					Kg.			A	B	C	D	E
Liberty 11	11	6800	4500	11300	6473	2533	2250	2256	2740	1030	614	3357
Liberty 12F	12	7200	4500	11700	6605	2678	2250	2256	2740	1030	614	3590
Liberty 13F	13	7200	4500	11700	6473	2828	2250	2256	2740	1030	614	3590
Liberty 13 XL	13	6900	4500	11400	6872	2650	2400	2500	2920	1050	584	4000

Engine	Mixing	Chopper	Driving	Cabin
Engine turbo diesel intercooler Deutz 3.6 TCD L121 04 H.P. water cooled 4 cylinders.	Variable hydrostatic Sauer pump and motor with 2 speeds mixing connecting axial to gearbox.	Spiral facer with Variable hydrostatic Bosch Rexroth pump with Cut - Off - Pressure and Reverse.	Front Drive with Bosch Rexroth hydrostatic motors and Variable hydrostatic pump 2 speeds up to 25Kph.	Luxury cabin with air conditioning, pneumatic Grammer seat and Otto switches.

**RMH**  
LACHISH INDUSTRIES LTD.

Email: [sales@lachish.com](mailto:sales@lachish.com)  
[www.rmhmixer.com](http://www.rmhmixer.com)

