



Self-Propelled  
**TRIPLE**

30-36 m<sup>3</sup>

**RMH mixers are designed for maximum efficiency and reliability.** With advanced features and a focus on seamless operation, they provide exceptional service and performance to maximize uptime.



### Three Axles, 6 Wheels

Triple axle system delivers balanced load distribution, increased capacity, and high stability. For feed volumes up to 36 m<sup>3</sup>.



### Operator Environment

Height-adjustable cabin for unmatched visibility & all day comfort with an ergonomic design.



### Eco

ECO mode with smart engine adaptation, optimizing power and fuel consumption. Advanced hydraulic system for precise\*.



### DuraCore Construction

Optional stainless steel auger, drum, conveyor, and contra-knives for extended wear resistance in all components.



### TMR

Maximal preservation of nutritional value, optimal fiber length & even distribution for livestock health and yield.



### Worldwide Service

Ensure maximum uptime with global spare parts availability and professional local technical support. Plus, quick-access for easy maintenance.

\*Based on comparative studies with leading competitor models. Results may vary based on operational conditions.



## Advanced Drive System

4x4 drive & 6-wheel steering for enhanced maneuverability

Triple axle configuration for optimized weight distribution and improved stability under heavy loads

Crab mode for better handling in narrow spaces

Superior ground clearance and traction for all-terrain operation



## Operator Environment

360° visibility with height-adjustable cabin.

Ergonomic work area.

Multi-camera system (rear, mixing chamber, optional sides).

Advanced suspension for all-day comfort.



## Smart Service Access

- Quick-access engine area.
- Comprehensive worldwide parts availability.
- Local expert technical support.
- Low maintenance design for maximum uptime and easy maintenance.



## Perfect Mix

- Overlapping vertical augers
- Integrated contra-knife for quicker mixing.
- Ensures homogeneous mix.
- Mixing bin top options (cover/fiber).
- 3CR12 stainless steel option.

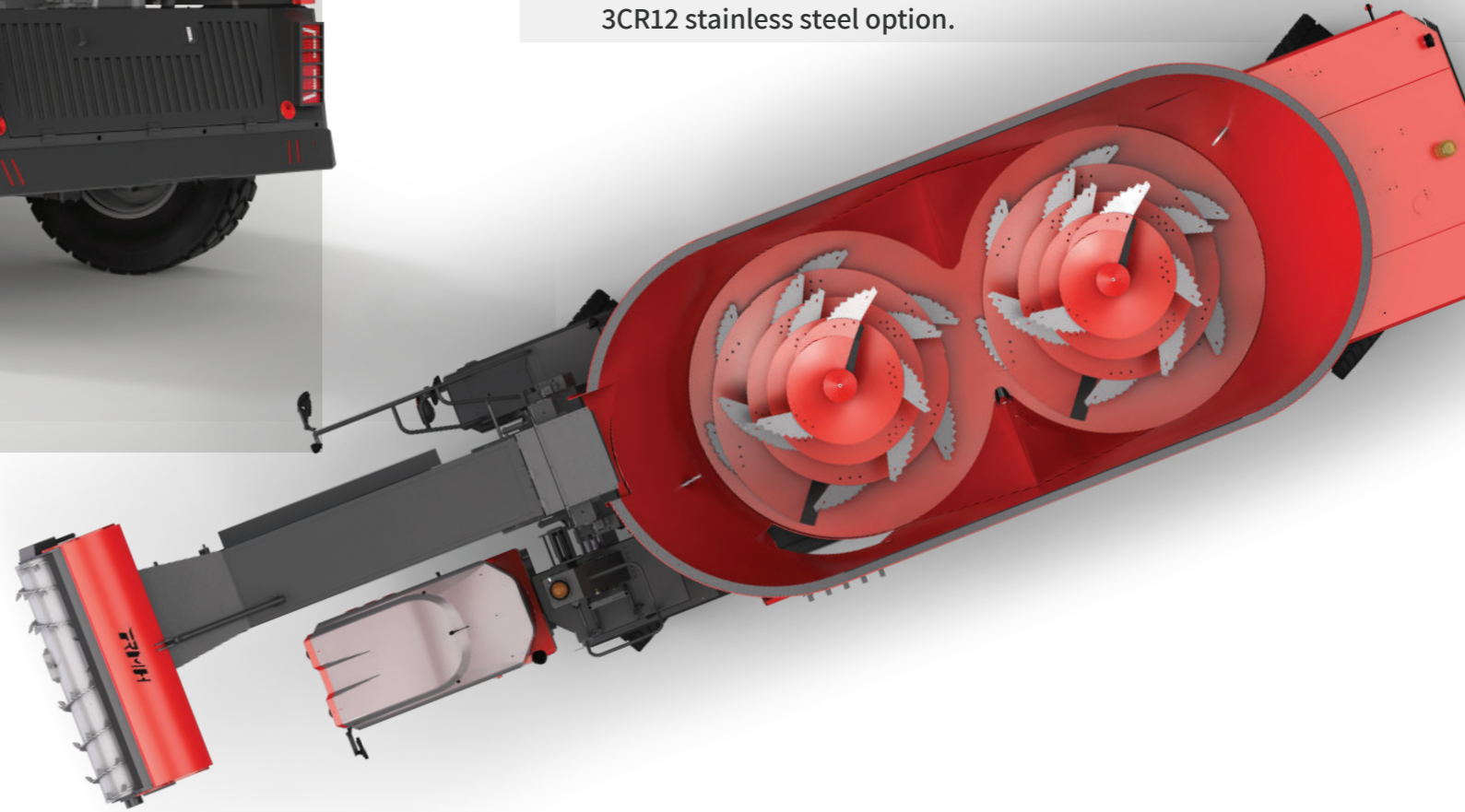

## SafeFeed

- Customizable distribution system: up to 4 doors and 3 portable conveyors for even feed distribution.
- Powerful magnets protecting cattle from metallic particles.



## CutControl

- Advanced feed harvesting
- Automatic precise loading option.
- Multiple loading speed options.
- 3CR12 stainless steel option.



## Vitamins Compartment

- Easy to add supplements.
- Enrich cattle yield and save time.



# TRIPLE Technical selfs data

Specifications	Triple 30	Triple 36
1 Volume [cu. mt.]	30	36
2 Max Load [kg]	12000	14400
3 Engine H.P	286	340
4 Engine Manufacturer	Volvo	
5 Overall Length [mm]	10800	11000
6 Overall Height [mm]	3620	3700
7 Overall Width [mm]	2800	2990
8 Chopper Width [mm]	2014	2250
9 Chopper Dia. [mm]	600	
10 Chopper Height [mm]	6000	
11 Loading Elevator Belt [mm]	650	800
12 Discharge Height [mm]	810	
13 Wheel Dia. [mm]	1150	
14 Wheel Base [mm]	5840	6150
15 Steering Radius [mm]	7250	
16 Ground Clearance [mm]	275	
17 Front Steering	Yes	
18 6 Wheel Steering	Yes	
19 Driving Speed [KPH]*	40	25
20 No. of STD Choper Knives	66	70
21 No. of STD Mixer Knives	15	16
22 Bin Wall 3CR12 [6 mm]	11	6
23 Mixer Segment Thickness [mm]	14/16	16
24 Mixer Speed [rpm]	15-50	
25 Elevated Cab.	Yes	
26 3CR12 Option	Augers, Chopper, Loader Elevation	

\*Suitable for farms only

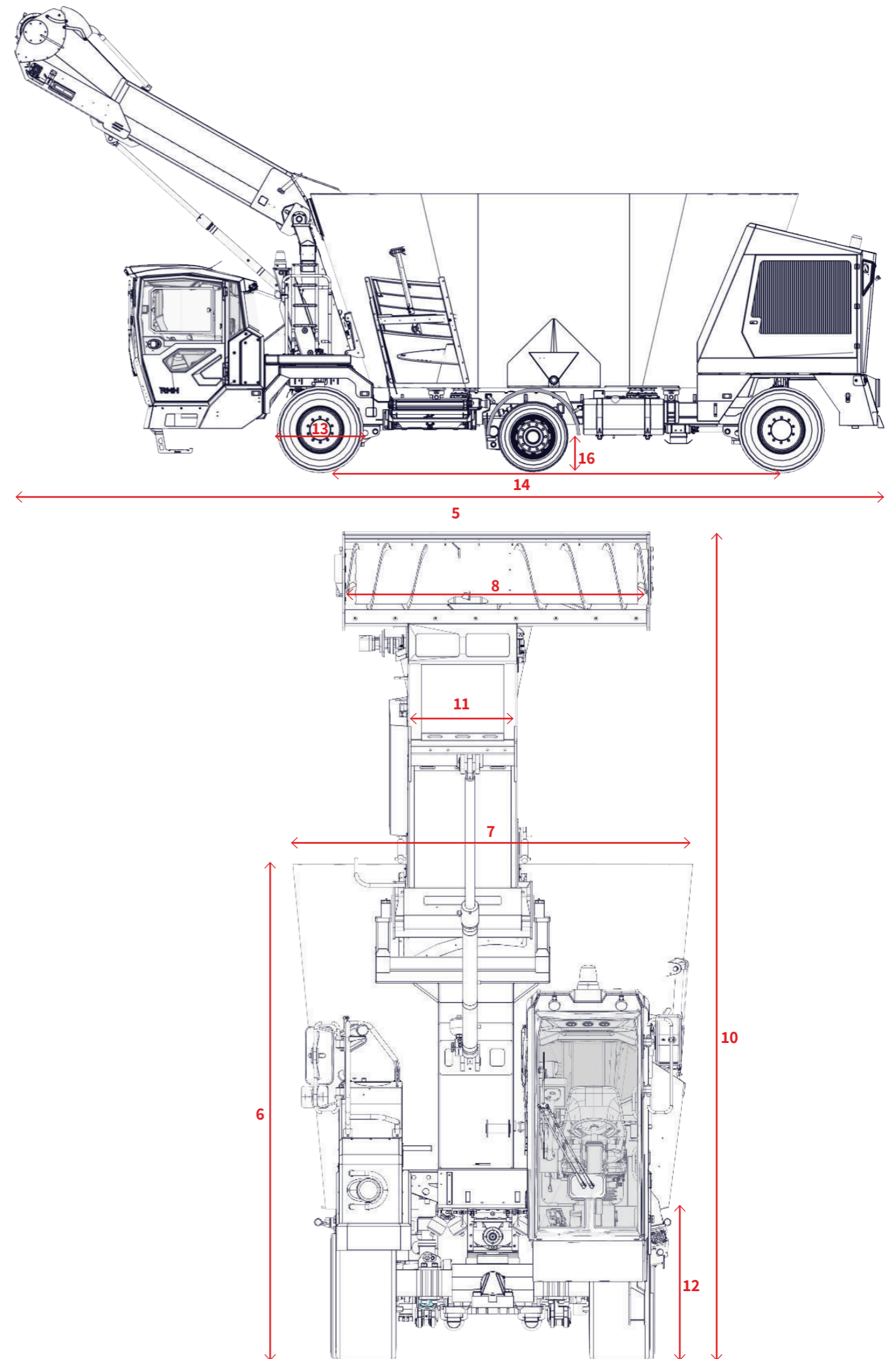



Follow Us

# About Us

Founded in 1956, RMH has built a strong legacy of over 60 years in manufacturing high-quality feed mixers for dairy farms worldwide. Committed to excellence, outstanding service, and maximum performance, RMH continues to set industry standards.

With two state-of-the-art production sites in Israel (Sderot) and Poland (AndoTech), along with a European subsidiary (RMH France) serving as a key marketing and operational hub, RMH ensures seamless global reach and support.

In 2023, RMH was recognized for its remarkable achievement of increasing share yield by more than 100% on the Tel Aviv Stock Exchange. As a pioneer in its field, RMH is dedicated to continuous innovation, developing advanced models that drive its sustained success.

The company invests heavily in cutting-edge technologies such as Galileo, Dairycs, and AgTech, reinforcing its leadership in the evolving agricultural landscape.



[WWW.RMHMIXER.COM](http://WWW.RMHMIXER.COM) | [INFO@RMHMIXER.COM](mailto:INFO@RMHMIXER.COM)

INDUSTRIAL ZONE SDEROT, P.O.B 105, 80100, ISRAEL

**Engineered for Performance, Backed by Service. Contact us for a personalized demo and experience the RMH difference!**